

6" MINIMUM FROM
EDGE OF CONCRETE

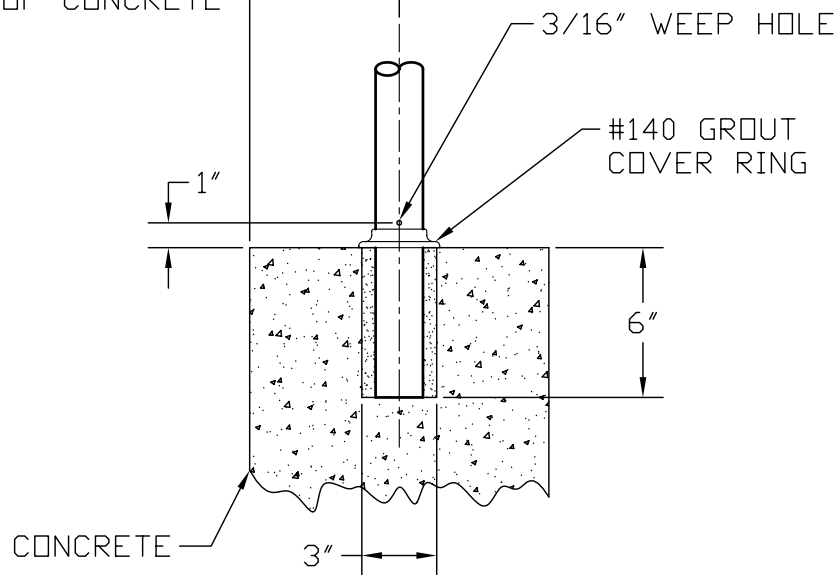

**CORE MOUNT
DETAIL**

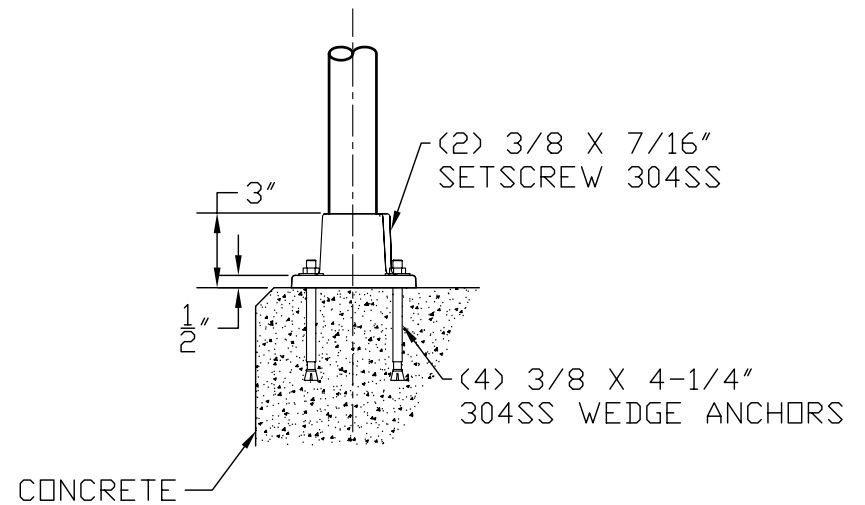
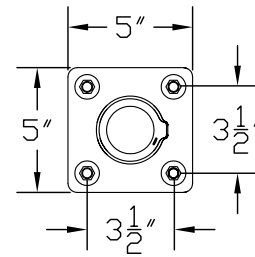

**#45SBC SQUARE BASE FLANGE
DETAIL**

THIS DRAWING AND ALL THE INFORMATION THEREON IS THE PROPERTY OF THE HOLLAEENDER MFG. CO., IS CONFIDENTIAL AND MUST NOT BE MADE PUBLIC, NOR COPIED, NOR USED, TO THE DISADVANTAGE OF SAID HOLLAEENDER MFG. CO. AND IS SUBJECT TO RETURN ON DEMAND.
COPYRIGHT 2004
HOLLAEENDER MANUFACTURING CO.

NO.	REVISIONS	DATE	APPROVED
A	ISSUED FOR REVIEW/APPROVAL	7-28-04	BW

Hollaender[®]
STRUCTURAL ENGINEERING GROUP

HOLLAEENDER MFG.
10285 WAYNE AVENUE
CINCINNATI, OH 45215-6399
PH: (800) 772-8800
FX: (800) 772-9806
WWW.HOLLAEENDER.COM

PROJECT
CH2MHILL

DESCRIPTION
DETAIL PACKAGE

DRAWN BY:	APPROVED BY:	DATE:
BW	BW	7-28-04
PROJECT NO: N/A	SCALE: NTS	
FROM: ANODIZED 215R1	DRAWING NO: 2994-D	
NATURAL: VARIES	SHEET 1	OF 27

